

## Section Two: Wind Energy

### What Is Wind Energy?

Wind energy is a renewable energy technology that converts the kinetic energy of moving air into electricity using wind turbines. It is considered a green energy source because it generates power without burning fossil fuels or releasing greenhouse gases during operation.



### How Wind Turbines Work



### Main components

- Rotor blades
- Nacelle (generator + gearbox)
- Tower
- Foundation

👉 Think of a wind turbine as a fan running in reverse — wind moves the blades to make electricity instead of electricity moving air.

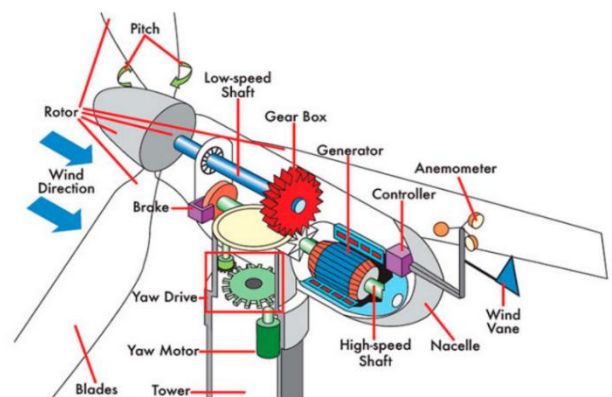

### Environmental Benefits of Wind Energy

- Renewable and inexhaustible resource.
- Produces electricity without carbon emissions during operation.
- Reduces reliance on fossil fuels and lowers climate impact.

### Types of Wind Turbine Technologies

## 1 Horizontal-Axis Wind Turbines (HAWT)

### Description

- Rotor spins around a horizontal axis.
- Blades face the wind directly.
- Most common design worldwide.

### Key Characteristics

- High efficiency and large electricity output.
- Used in utility-scale wind farms.
- Require yaw systems to face the wind.

### Applications

- Onshore wind farms
- Offshore wind farms
- Large industrial projects

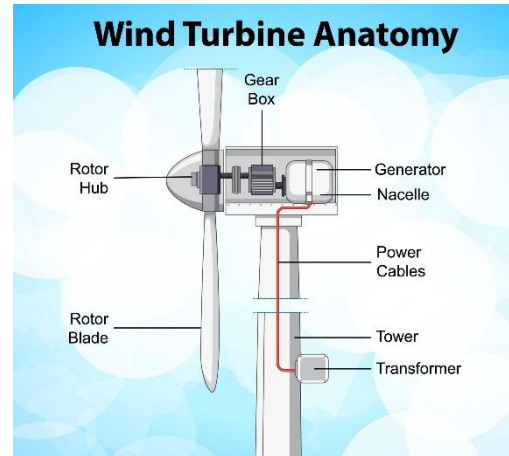

## 2 Vertical-Axis Wind Turbines (VAWT)

### Description

- Rotor spins around a vertical shaft.
- Can accept wind from any direction.
- Generator often placed near the ground.

### Advantages

- Works well in turbulent or urban wind conditions.
- Easier maintenance due to lower mechanical placement.

### Applications

- Urban rooftops
- Small-scale energy systems
- Experimental smart-city projects

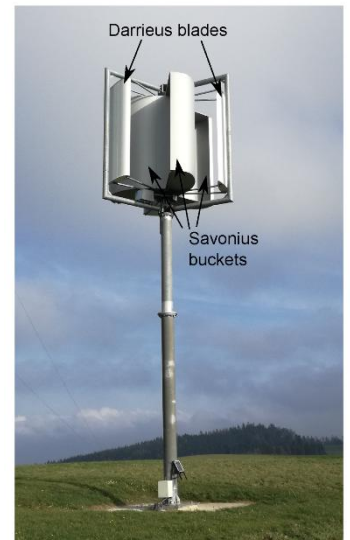

## Major Wind Energy Applications

Wind energy is not only about big wind farms — it has multiple applications across energy systems.

### 1. Utility-Scale Onshore Wind Power

#### Description

Large wind farms built on land generate electricity for the national grid.



#### TYPES OF VERTICAL AXIS WIND TURBINES

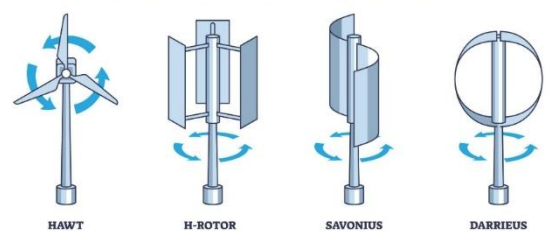

#### How It Works

- Multiple turbines connected through underground cables.
- Electricity sent to transformers and distribution networks.

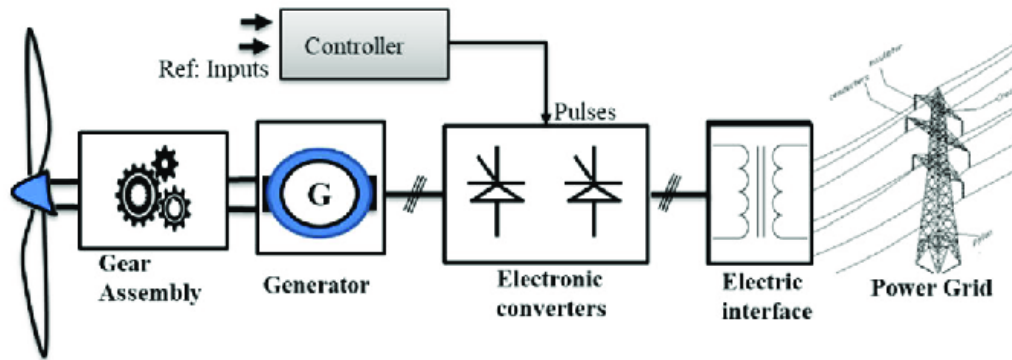

### Advantages

- Lowest-cost renewable electricity sources.
- Land beneath turbines can still be used for farming.

### Typical Locations

- Plains, coastal regions, hills

## 2. Offshore Wind Energy

### Description

Wind turbines installed in oceans or seas to capture stronger winds.



### Types of Offshore Systems

- Fixed-bottom turbines (shallow waters)
- Floating turbines (deep waters)

### Benefits

- Stronger and more consistent wind speeds increase power output.
- Less visual and land-use conflict.

### Applications

- National electricity supply
- Large coastal energy projects
- Hybrid offshore energy systems

### TYPES OF OFFSHORE WIND TURBINES

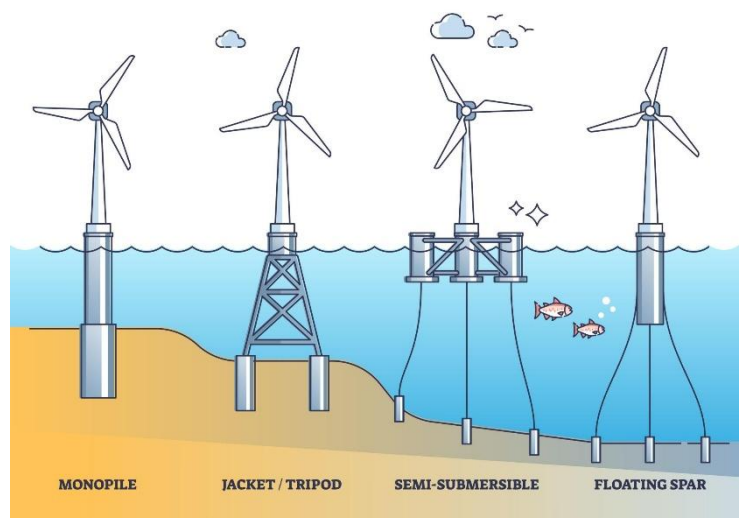

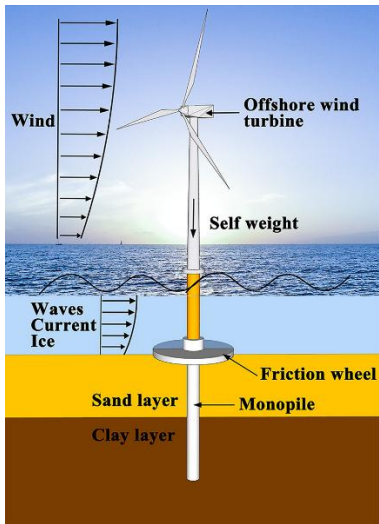

### 3. Small-Scale and Residential Wind Systems

#### Description

Small turbines (<100 kW) provide local electricity for homes or businesses.

#### Key Uses

- Off-grid homes
- Farms and rural communities
- Microgrids combined with solar panels and batteries

Small wind systems can reduce electricity costs and improve energy independence.



### 4. Mechanical Applications (Non-Electric Uses)

#### Description

Wind energy can directly perform mechanical work instead of generating electricity.

#### Examples

- Water pumping for agriculture
- Grain grinding (traditional windmills)
- Irrigation systems

Wind pumps can lift hundreds of litres of water per hour for farms.

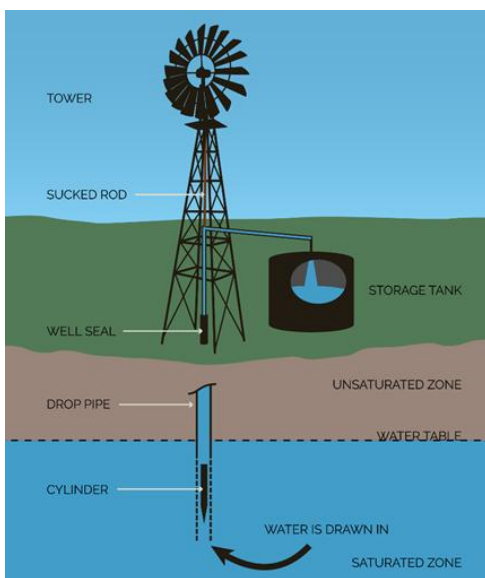

### 5. Hybrid and Emerging Wind Applications

## Description

New technologies combine wind power with other renewable systems.

## Key Innovations

- Wind-solar hybrid farms
- Renewable hydrogen production using wind electricity
- Bladeless wind turbines
- Floating offshore systems

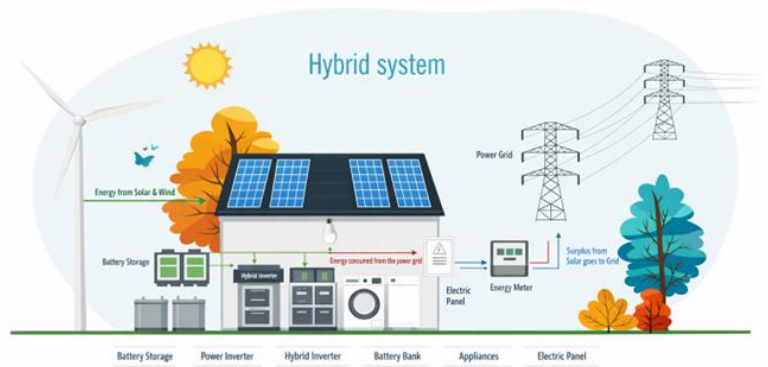

Hybrid renewable projects can increase overall energy efficiency and reliability.



## Environmental Benefits of Wind Energy

- Renewable and inexhaustible resource.
- Produces electricity without carbon emissions during operation.
- Reduces reliance on fossil fuels and lowers climate impact.

## Challenges and Limitations

Even green technologies have drawbacks:

- Wildlife impacts (birds and bats).
- Noise and visual concerns.
- Variable energy output depending on wind conditions.
- Grid integration complexity.